

WA6013-8

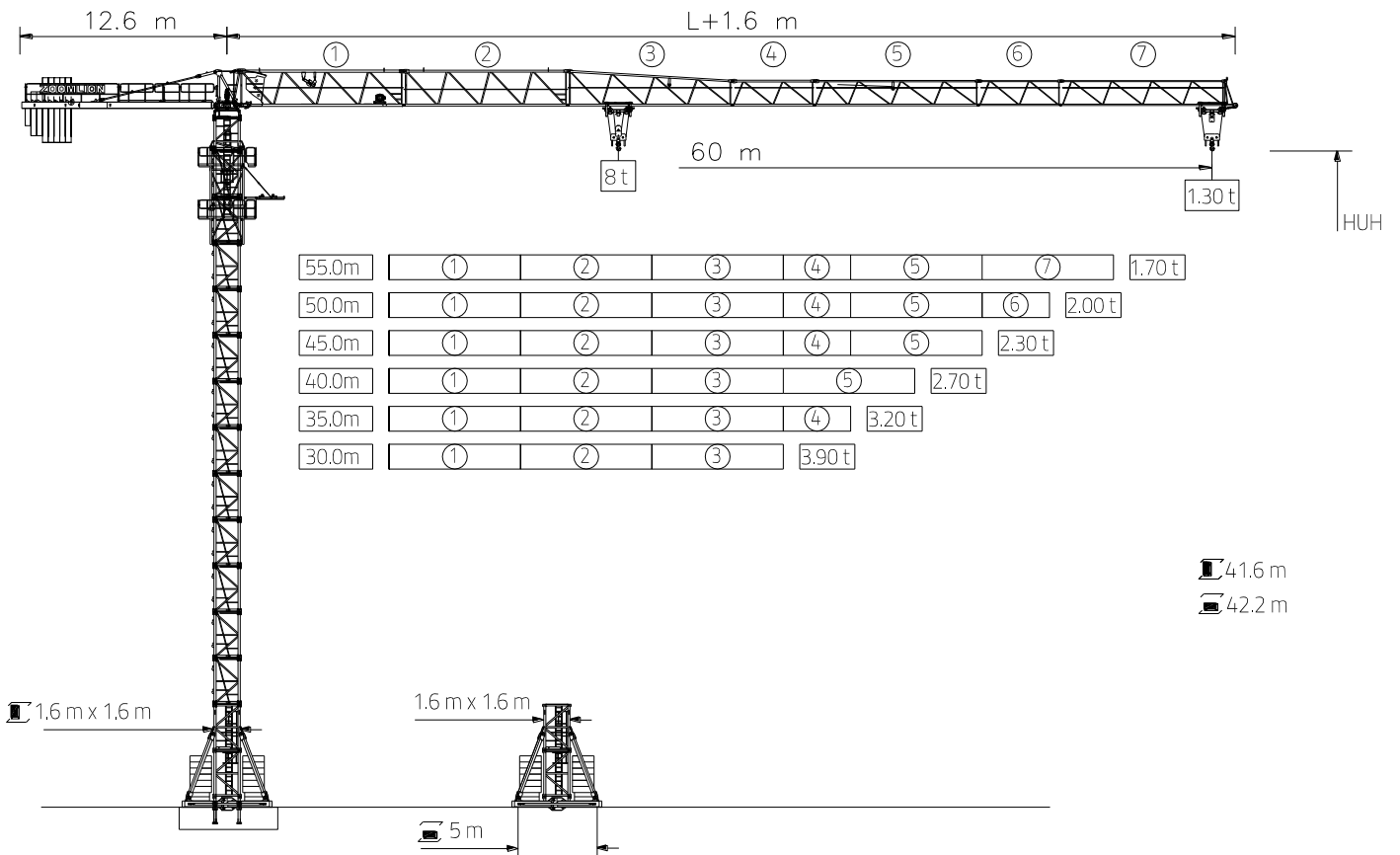

Mast Reactions

1.6 m

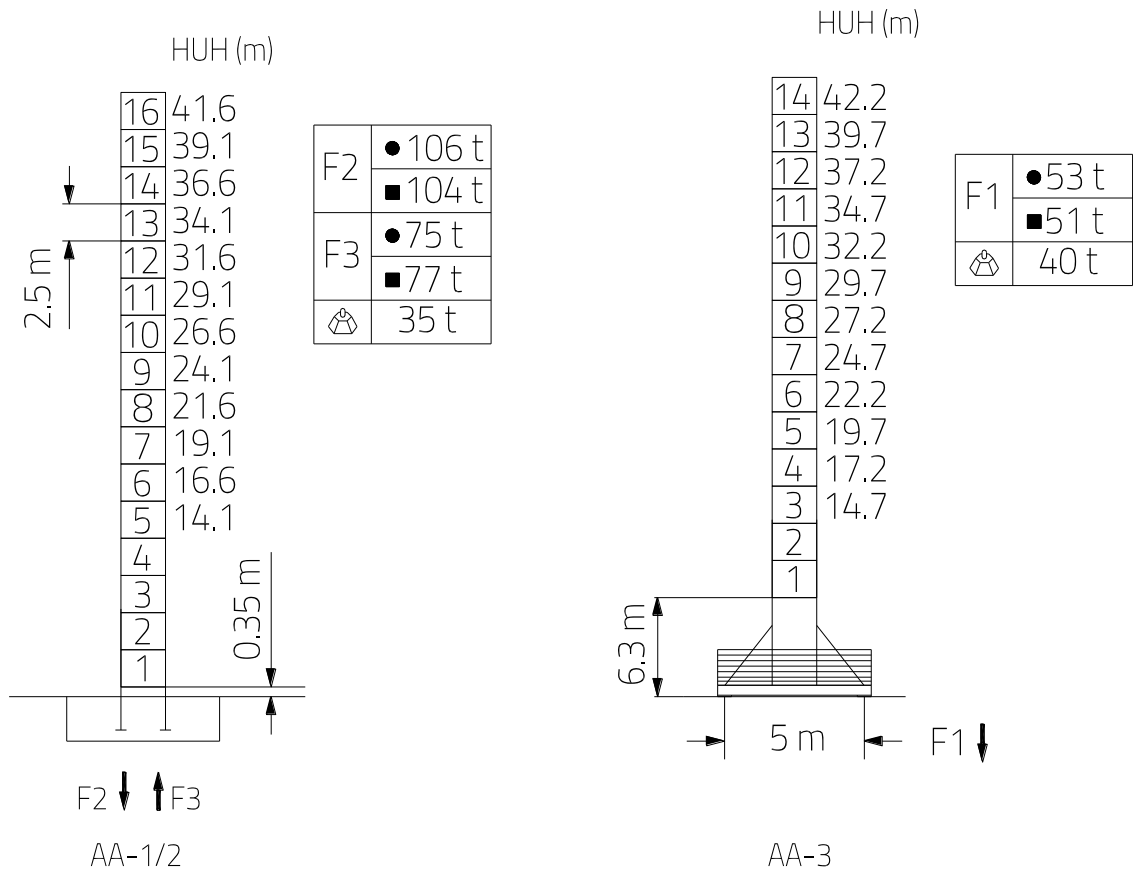

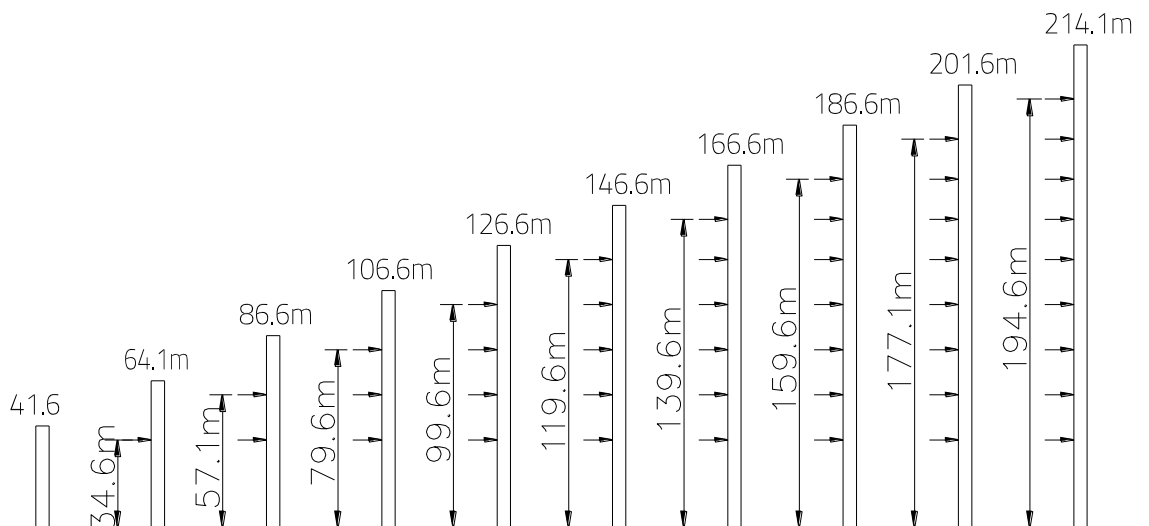

Anchorage

1.6 m

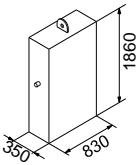
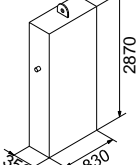
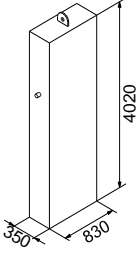

Counter-jib Ballast

	2.8 t	2.0 t	1.3 t	 (t)	PHZ1300	PHZ2000	PHZ2800
60.0 m	4	2	2	17.8			
55.0 m	4	2	1	16.5			
50.0 m	4	1	2	15.8			
45.0 m	4	1	1	14.5			
40.0 m	4	1	0	13.2			
35.0 m	3	1	1	11.7			
30.0 m	2	1	2	10.2			

Ground Ballast

Base Type	H (m)	 (t)
AA-3	24.7	20.8
	27.2	27.6
	29.7	27.6
	32.2	34.4
	34.7	34.4
	37.2	41.2
	39.7	48.0
	42.2	54.8

Dimensions and Weights

Slewing crane parts

 x 1

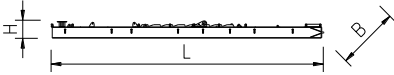
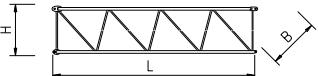
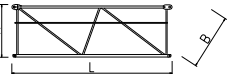

 x 2

 x 3

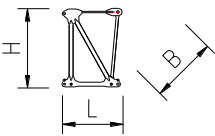
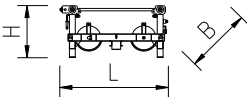
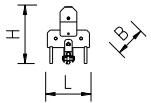
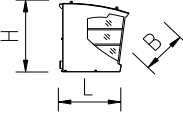
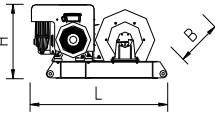
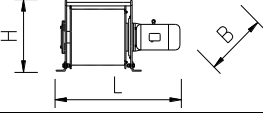
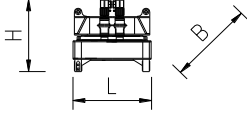

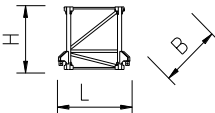
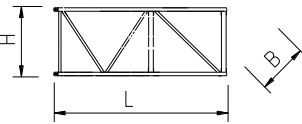
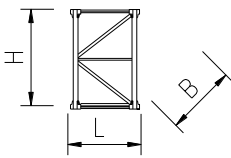

Slewing crane parts		L (m)	B (m)	H (m)	Weight (kg ±5%)	
Counter-jib		11.83	1.10	0.60	2850	
Jib section		G1	10.24	0.98	2.47	1920
		G2	10.20	0.98	2.33	1390
		G3	10.18	0.98	2.23	1020
		G5	10.16	0.98	1.60	760
		G7	10.15	0.98	1.57	500
		G4	5.18	0.98	1.62	500
		G6	5.16	0.98	1.57	270
		G8	0.87	0.98	1.76	100

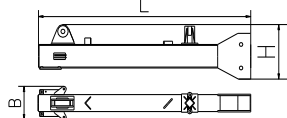
Tower head			1.71	1.60	2.04	880
Trolley			2.03	1.67	0.90	280
Hook block			0.93	0.36	1.54	290
Cabin			2.08	1.30	2.16	480
Hoisting mechanism		H30FP20-430P(TPTC)	1.50	1.71	0.88	1450
Trolleying mechanism		T40FC65-b(D)	1.08	0.73	0.57	370
Slewing assembly		1.6 m	1.74	2.03	1.96	3200

Tower type EQ

Crane tower parts		L (m)	B (m)	H (m)	Weight (kg ±5%)
Connecting section	 1.6 m	2.08	2.14	2.80	1130
Telescoping cage	 1.6 m	5.94	2.08	2.38	2640
EQ7H(TPTC)	 1.6 m	1.79	1.74	2.50	845
EQ8B(TPTC)		1.79	1.74	2.80	880
Whole beam		8.94	1.00	0.83	1690
Semi beam	 2x	4.33	0.51	0.93	800

Mechanisms

			b		b		kW	
	H30FP20-430P(TPTC)	t	1	4	2	8	30	430 m
		m/min	100	40	50	20		
	S40CA-100LA10/12A	r/min	0-0.8				2×4.0	
	S40CN-100LA10/12A							
	T40FC65-b(D)	m/min	0-100				4.0	
	380 V(±10%) 50Hz	H30FP20-430P		42.0 kW (excluding climbing)				

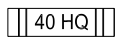

High cube 40'



Total weight without ballast

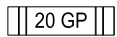

General Purpose 20'



Counter weight



Lorry 13.4 m



Ground ballast



Reactions in service



Hoisting



Reactions out of service



Slewing



Fish plate tower section



Trolleying



Bolt tower section



Travelling



Tenon tower section



Consult us