

■ S02200 - 2.20x2.20 m  
 ○ SR2500 - 2.50x2.50 m

H=Altezza sotto gancio  
 H=Height under hook  
 H=Hauteur sous crochet



Torre/Reazioni | Masts/Reactions | Mat/Réactions | Maste/Eckdrücke | Mástil/Reacciones | Tramo/Reacções

**SO2200**



		Torre/Masts/Mat/Maste/Mástil/Tramo										
 TRO	H[m]	4f/4f BF055	4f/4f SB055	4f/4f ST055	4f/4f STB055	4f/4f RA055						
	48			8								
 TTD	H[m]											

		Torre/Masts/Mat/Maste/Mástil/Tramo										
 CAF	H[m]	4f/4f BF055	4f/4f SB055	4f/4f ST055	4f/4f STB055	4f/4f RA055						
	47.3			7								
 R2	H[m]											

		Torre/Masts/Mat/Maste/Mástil/Tramo										
 R1	H[m]	4f/4f BF055	4f/4f SB055	4f/4f ST055	4f/4f STB055	4f/4f RA055						
	42			6								
 CATR	H[m]											

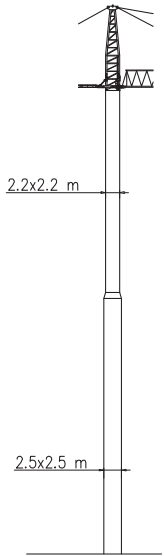

H=0-48 m	
R1	120 t
R2	120 t
R3	150 t
M	634 tm

Peso zavorra | Ballast weight | Poids du lest | Ballastgewicht | Peso de lastre

	H	Tot.
	0-48 m	102320 kg



Torre/Reazioni | Masts/Reactions | Mat/Réactions | Maste/Eckdrücke | Mástil/Reacciones | Tramo/Reações

**SR2500**

47.6 m → 70 m

		Torre/Masts/Mat/Maste/Mástil/Tramo					
 TRO	H[m]	4f/4f BF055	4f/4f SB055	4f/4f ST055	4f/4f STB055	4f/4f RAO55	
		59		ø			
 TTD	H[m]						

		Torre/Masts/Mat/Maste/Mástil/Tramo					
 CAF	H[m]	4f/4f BF055	4f/4f SB055	4f/4f ST055	4f/4f STB055	4f/4f RAO55	
		68		ø			
 CAF	H[m]						

		Torre/Masts/Mat/Maste/Mástil/Tramo					
 CATR	H[m]	4f/4f BF055	4f/4f SB055	4f/4f ST055	4f/4f STB055	4f/4f RAO55	
		63.5		ø			
 CATC	H[m]						

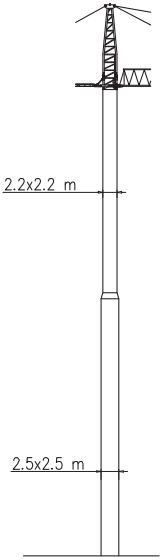

H=0-48 m	H>48 m
R1 120 t	Contact us
R2 120 t	
R3 150 t	
M 634 tm	

**Peso zavorra | Ballast weight | Poids du lest | Ballastgewicht | Peso de lastre**

H	Tot.
0-69 m	102320 kg



**Curve di carico | Courbes de charges | Load diagrams | LastKurven | Curvas de cargas**

P<sub>max</sub> 20000/10000 kg

	32630 kg		70 m	3.5	30	32	34	36	38	40	42	44	46	48	50	52	54	56	58	60	62	64	66	68	70	m	
				20000	8600	7500	6000	5500	4680	3800	3000	2500	2000	1000	0800	0500	0000	9600	8800	8400	8000	7800	7500	7000	kg		
	30120 kg		64.4 m	3.5	30	32	34	36	38	40	42	44	46	48	50	52	54	56	58	60	62	64.4				m	
				20000	8600	7500	6000	5500	4680	3800	3000	2500	2000	1000	0800	0500	0000	9600	8800	8400	7900				kg		
	27610 kg		58.8 m	3.5	30	32	34	36	38	40	42	44	46	48	50	52	54						58.8				m
				20000	8600	7500	6000	5500	4680	3800	3000	2500	2000	1000	0800	0500	0000						9500				kg
	27610 kg		53.2 m	3.5	30	32	34	36	38	40	42	44	46	48	50	52	53.2									m	
				20000	8600	7500	6000	5500	4680	3800	3000	2500	2000	1000	0800	0000									kg		
	25100 kg		47.6 m	3.5	30	32	34	36	38	40	42	44	46	47.6									m				
				20000	8600	7500	6000	5500	4680	3800	3000	2500	2000									kg					

P<sub>max</sub> 24000/12000 kg

	32630 kg		70 m	3.5	22	30	32	34	36	38	40	42	44	46	48	50	52	54	56	58	60	62	64	66	68	70	m	
				24000	20000	8600	7500	6000	5500	4680	3800	3000	2500	2000	1000	0800	0500	0000	9600	8800	8400	8000	7800	7500	7000	kg		
	30120 kg		64.4 m	3.5	22	30	32	34	36	38	40	42	44	46	48	50	52	54	56	58	60	62	64.4				m	
				24000	20000	8600	7500	6000	5500	4680	3800	3000	2500	2000	1000	0800	0500	0000	9600	8800	8400	7900				kg		
	27610 kg		58.8 m	3.5	22	30	32	34	36	38	40	42	44	46	48	50	52	54	56	58.8						m		
				24000	20000	8600	7500	6000	5500	4680	3800	3000	2500	2000	1000	0800	0500	0000						9500				kg
	27610 kg		53.2 m	3.5	22	30	32	34	36	38	40	42	44	46	48	50	52	53.2									m	
				24000	20000	8600	7500	6000	5500	4680	3800	3000	2500	2000	1000	0800	0000									kg		
	25100 kg		47.6 m	3.5	22	30	32	34	36	38	40	42	44	46	47.6									m				
				24000	20000	8600	7500	6000	5500	4680	3800	3000	2500	2000									kg					

Pesi e ingombri | Packing list | Liste de colisage | Gewicht und abmessungen

Denominazione Description	Disegno Draw	Pezzi Pieces	Dimensioni-Dimensions (mm)			Peso-Weight (kg)		
			L	W	H	Unit	Total	
Elemento di braccio Jib element Elément de èche Elemento de flecha	n°1		1	5900	2300	2500	2350	-
	n°2		1	5900	2300	2500	1800	-
	n°3		1	5900	2300	2500	2100	-
	n°4		1	5900	2300	2500	2400	-
	n°5		1	5900	2300	2500	1930	-
	n°6		1	5900	2300	2500	1920	-
	n°7		1	5900	2300	2500	1600	-
	n°8		1	5900	2300	2500	1550	-
	n°9		1	5900	2300	2500	1420	-
	n°10		1	5900	2300	2500	1400	-
	n°11		1	5900	2300	2500	1370	-
	n°12		1	5900	2300	2500	1350	-
	Punta		1	4300	2300	2500	1150	-
Tirante completo Complete tie rod Tirant complète Tirante completo		-	6500	200	200	240	9550	
Cuspide Cusp Pointre Cùspide		1	10050	2000	2000	6800	-	
Contorbraccio 1 Counterjib 1 Contreflèche 1 Contraflecha 1		1	6000	1750	1500	3500	-	
Contorbraccio 2 Counterjib 2 Contreflèche 2 Contraflecha 2		1	4500	1750	1500	900	-	
Contorbraccio 3 Counterjib 3 Contreflèche 3 Contraflecha 3		2	5900	1750	1500	1150	2300	
Contorbraccio 4 Counterjib 4 Contreflèche 4 Contraflecha 4		1	6120	1750	1500	2600	-	
Gruppo girevole Slewing group Table tournante Grupo giratorio		SO2200	1	2320	2320	3150	12100	-
		SR2500	1	2320	2320	3150	12500	-

## Pesi e ingombri | Packing list | Liste de colisage | Gewicht und abmessungen

Denominazione Description	Disegno Draw	Pezzi Pieces	Dimensioni-Dimensions (mm)			Peso-Weight (kg)			
			L	W	H	Unit	Total		
Carrello Trolley Chariot Carretilia		1	4300	2700	1800	3200	—		
Ballatoio con cabina Access balcony with cabin Porte cabine Balcón corrido con cabina		1	2500	2150	2450	1000	—		
Blocchi contrappeso Counterweight block Contre-poids Bloques de contrapeso	VX25 	13	2000	300	2260	2510	32630		
Elemento di torre Mast element Elément de mât Elemento de torre	ST055 	S02200	—	5500	2200	2200	5100	—	
	SR2500	—	5500	2500	2500	5400	—		
	SB055 	S02200	—	5500	2200	2200	5530	—	
	SR2500	—	5500	2500	2500	5670	—		
Elemento di base Base element Mat de base Elemento de base		BF055	S02200	—	5500	2200	2200	5890	—
		SR2500	—	5500	2500	2500	6230	—	
Elemento di base Base element Mat de base Elemento de base		BA055	S02200	1	5500	2200	2200	5890	—
		SR2500	1	5500	2500	2500	6230	—	
Carro di base Base carriage Chassis de base Cruceta de base			1	14200	1000	1000	—	—	
			2	6500	1000	1000	—	—	
Puntoni di base Rafter Jambes de force Cabrios de base		4	7250	500	500	—	—		
Elemento a perdere Disposable frame Chassis a perdre Bastidor desechable		S02200	1	2600	2200	2200	1430	—	
		SR2500	1	2600	2500	2500	2030	—	
Elemento recuperabile Recoverable frame Chassis récupérable Bastidor recuperable		S02200	1	1300	2170	2170	1720	—	
		SR2500	1	1300	2620	2620	1860	—	
Bogie di traslazione Driven bogie Bogîe motorisèe Balancin de traslaciòn		4	1160	700	600	700	2800		
Blocco zavorra di base Base ballast block Lest de base Blaque de lastre			2	—	—	—	—	—	
			2	—	—	—	—	—	
			—	—	—	—	—	—	
			—	—	—	—	—	—	
Corsoio di montaggio Climbing cage Cage de montage Jaula de montaje		S02200	1	8300	2600	2500	7500	—	
		SR2500	1	8300	2900	2700	8000	—	

**Gru in cavedio | Télescopage sur dalles | Climbing crane | Kletterkrane im Gebäude**

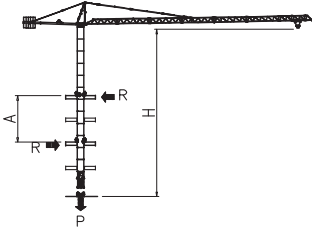

SN2050	H (m)	A (m)	R (°)	P (°)
	9	45.3		
	10	42		
	11	39.3		
	12	37		
	13	35		
	14	33.4		
	15	32		
	16	30.7		
	17	29.6		
	18	28.6		
	19	27.8		
20	27			
		50.8		

**Sopralzo idraulico | Telescopic | External climbing | Kletterkrane**

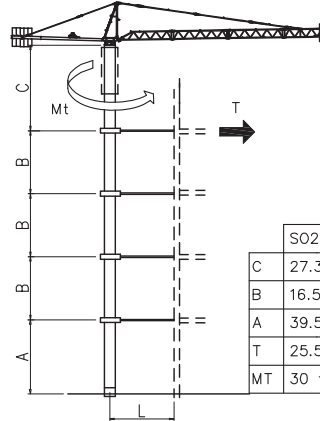
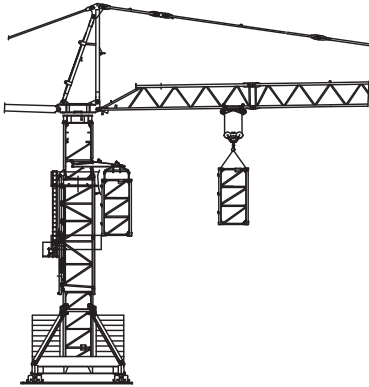

	S02200	SR2500
C	27.3 m	31.2 m
B	16.5 m	16.5 m
A	39.5 m	39.5 m
T	25.5 m	30 m
MT	30 txm	29 txm

**Montaggio | Montage | Erection | Montage | Montaje | Montagem**

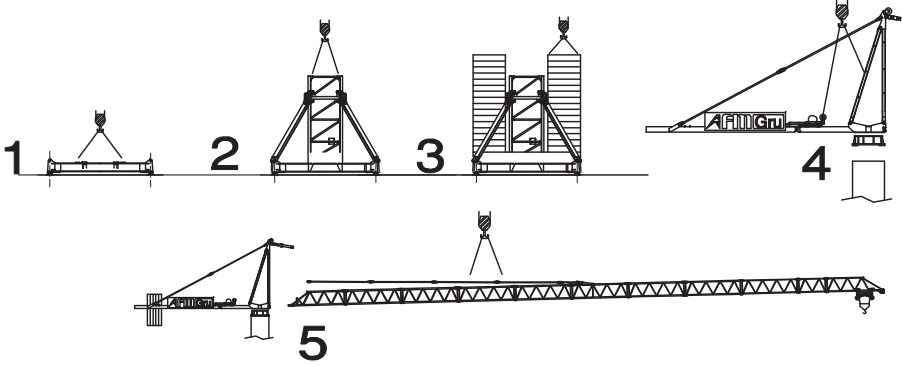

**Meccanismi | Mechanisms | Mécanismes | Antriebe | Mecanismos**

Sollevamento V100.130 Hoisting Levage Heben Elevaciòn Elevaçao							 m/min: 70, 60, 50, 40, 20 t: 2, 4, 6, 8, 10, 12	V100.130 75 kW 110 kVA  360 m 750 m (L)	
	m/min	3	14	27	43	57			65
	t	12	12	12	8	5,6			2,8
	m/min	1.5	7	13.5	21.5	28.5			32.5
t	24	24	24	16	11.2	5,6			
Sollevamento V130.100 Hoisting Levage Heben Elevaciòn Elevaçao							 m/min: 100, 80, 60, 50, 40, 20 t: 4, 6, 8, 10	V130.100 95 kW 136 kVA  360 m 750 m (L)	
	m/min	4	44	62	78	100			—
	t	10	10	8	6	4,5			—
	m/min	2	22	31	39	50			—
t	20	20	16	12	9	—			

Carrello Trolleying Distribution Katzfahren Distribuciòn Distribuiçao			0 → 100	m/min	11 kW	Potenza elettrica necessaria Puissance électrique nécessaire Necessary electric power Anschlusswert – Potencia
Rotazione Slewing Orientation Schwenken Orientaciòn Rotaçao			0 → 0,9	giri/min tr/min rp/min	8.8 kW @ 1200rpm n° 4 x 2.2 kW	
Traslazione Travelling Translation Kranfahren Traslaciòn Traslaçao			0 → 20	m/min	7.5 kW	

**Rete elettrica | Réseau | Mains supply | Netzstrom | Red | Rede electrica** **400 V - 50 Hz**